



Subscribe to Caron Connections, our free e-newsletter.

Enter your e-mail address

subscribe

[yarn](#) [free projects](#) [where to buy](#) [links](#) [learning](#) [contact us](#) [caron connections](#) [news](#) [latch hook](#)

Caron Yarns

Simply Soft®

Simply Soft® Baby **NEW**

Simply Soft® Brites

Simply Soft® Heather

NEW

Simply Soft® Quick

Simply Soft® Tweed

Simply Soft® Shadows

Bliss

Craft & Rug Yarn **NEW**

Felt-It

Fling

Glimmer

Natura®

One Pound

Perfect Match®

Pizazz

Wintuk®

Caron Latch Hook Kits

Shaggy **NEW**

Caron® Classics

Natura®

WonderArt®

Krafty Kids®

Christmas designs

Jubilee Jacket & Scarf Set

with
CHARMING
and
SIMPLY SOFT®

Designed by Kathy Perry

TECHNIQUE USED: Knit

Jacket:



EXPERIENCED

Scarf:



BEGINNER



click to enlarge image
schematic/chart

image courtesy of Creative Knitting

Printer Friendly PDF

SIZE

Woman's small (medium, large)

KNITTED MEASUREMENTS

Jacket:

Chest/Bust 34 (38, 42) inches

Length 20 (21, 22) inches

Scarf:

Approximately 4 1/2 inches wide by 44 inches long, excluding fringe

PLEASE NOTE: One or more yarns used in this project have been discontinued. You may be able to locate it at ShopCaron.com or selected retail locations, but supplies are limited. If you wish to make this project using a substitute yarn, please go to the Yarn Substitution Chart. Please keep in mind that you should always begin with a gauge swatch and be sure to convert yardage for any substitute yarn.

MATERIALS

Caron International's Simply Soft (100% acrylic; 6oz/170 g, 330 yds/304 m):

#9727 Black (MC), 2 (2, 3) skeins



Buy all your favorite
Caron products online

#9730 Autumn Red, (CCA), 1 skein all sizes for cord
 Caron International's Charming (100% nylon; 1.75 oz/50 g, 55 yds/50 m):
 #0011 Jubilee (CCB), 3 skeins, all sizes
 Size US 7 and 10 (4.5 and 6 mm) straight needles or size to obtain gauge
 Tapestry needle (tn)
 Embellish-Knit! Automatic spool knitter for i-cord (optional)
 Sewing needle and thread to match i-cord
 Two - size US 7 (4.5 mm) double pointed needles for working i-cord by hand using I-cord method

GAUGE

In Stockinette stitch, using smaller needles and MC, 18 sts and 23 rows = 4 inches/10 cm

In Stockinette stitch, using larger needles and CCB, 13 sts and 21 rows = 4 inches/10 cm

To save time, take time to check gauge

SPECIAL TERM

Wrap and Turn (wrp-t)

(WS rows) Yarn back (to the knit position), slip next st to RH needle, yarn forward (to the purl position), return slipped st, (which is now wrapped), to LH needle; turn, leaving rem sts unworked.

(RS rows) Yarn forward (to the purl position), slip next st to RH needle, yarn back (to the knit position), return slipped st, (which is now wrapped), to LH needle; turn, leaving rem sts unworked.

SPECIAL TECHNIQUE

Short Row Shaping

Work the number of sts indicated in the instructions, wrp-t. Return to starting point.

Continue to work progressively longer rows as indicated in the instructions; work wraps together with wrapped sts as you come to them, as follows: Insert the RH needle into wrap at base of wrapped st from beneath, then bring RH needle up and into st on LH needle ready to work the st; knit (or purl) wrap and st together—this prevents a hole from forming where Short Row ended.

Hint: If it's difficult to work wrap and st tog as given above, slip wrapped st to RH needle, insert LH needle into wrap (from bottom to top), place wrap on LH needle, return wrapped st to LH needle and knit (or purl) wrap and wrapped st together.

STITCHES USED

Stockinette stitch (St st)

Sand Stitch (see Chart)

(multiple of 6 sts + 5; 12-row repeat)

Row 1 (RS): K5, * p1, k5; repeat from * across.

Rows 2, 4 and 6: Purl.

Rows 3 and 5: Knit.

Row 7: K2, * p1, k5; repeat from * across, ending last repeat k2 instead of k5.

Repeat Rows 1 – 12 for Sand st.

NOTES

Garment is worked in five pieces, using MC; the back, 2 fronts and 2 sleeves.

CC trim is worked separately, using CCB, and attached to garment pieces. Cord is worked last, using CCA, and attached along seams between MC and CCB sections.

BACK

Using smaller needles and MC, cast on 77 (89, 101) sts.

(WS) Purl 1 row.

(RS) Beg Sand st, Row 6 (1, 1); work even until piece measures 8 (8 1/2, 9) inches from beg, ending with a WS row.

Shape armhole

(RS) Bind off 5 sts at beg of next 2 rows —67 (79, 91) sts remain.

Work even until armhole measures 6 (6 1/2, 7) inches from shaping, ending with a WS row; place a marker (pm) each side of center 27 (31, 33) sts.

Shape neck

(RS) Work across to marker; join a second ball of yarn and BO center sts; work to end.

Working both sides at same time, at each neck edge, dec 1 st ER 13 times —7 (11, 16) sts remain each shoulder. Work even until armhole measures 9 (9 1/2, 10) inches from shaping.

Bind off rem sts.

Left Front

Using smaller needles and MC, cast on 29 (33, 41) sts.

(WS) Purl 1 row.

(RS) Beg Sand st, Row 6 (1, 1); work even until piece measures 8 (8 1/2, 9) inches from beg, ending with a WS row.

Shape armhole and neck

(RS) Bind off 5 sts at armhole edge (beg of RS row), work across to last 3 sts at neck edge; ssk, k1. Work 2 rows even.

(WS) At neck edge, p1, ssp, work to end. Work 2 rows even.

(RS) Cont as est at neck edge, dec 1 st this row, then every 3 rows 14 (14, 17) times—7 (11, 16) sts remain for shoulder.

Work even until armhole measures 9 (9 1/2, 10) inches from shaping.

Bind off rem sts.

Right front

Work as for left front, reversing all shaping; work neck dec at beg of RS rows by: k1, k2tog; at end of WS rows by: p2tog, p1.

SLEEVES

Using smaller needles and MC, cast on 53 sts.

(WS) Purl 1 row.

(RS) Beg Sand st, Row 6 (6, 6); work 2 rows even, ending with a WS row.

Shape sleeve

(RS) Inc 1 st each side this row, then every 4 rows 2 (3, 17) times, every 5 rows 12 (13, 2) times—83 (87, 93) sts.

Work even until piece measures 14 (15, 16) inches from beg.

Bind off all sts loosely.

BACK— Lower edge CC trim

Using larger needles and CCB, cast on 55 (64, 73) sts.

(RS) Beg St st; work even until piece measures 3 inches from beg.

Bind off all sts loosely. Sew trim to lower edge of Back.

BACK— Neck CC trim

Using larger needles and CCB, cast on 19 (21, 23) sts.

(RS) Beg St st; work 1 row even.

Shape trim

Inc 1 st each side this row, then ER 9 times—39 (41, 43) sts.

Work even until piece measures 3 inches from beg.

Bind off all sts loosely.

Pm 3 inches in from each outer edge of trim on bind off row, to line up with front trim when sewing shoulders. Sew trim to back neck, matching shaping.

SLEEVES— Lower edge CC trim (make 2)

Using larger needles and CCB, cast on 36 sts.

(RS) Beg St st; work even until piece measures 3 inches from beg.

Bind off all sts loosely. Sew trim to lower edge of sleeves.

LEFT FRONT— CC trim

Using larger needles and CCB, cast on 31 (34, 37) sts.

(RS) Beg St st; work even until piece measures 3 inches from beg, ending with a WS row.

(RS) Bind off 20 (23, 26) sts, work to end—11 sts remain for front edge.

Work even until piece measures 11 (11 1/2, 12) inches from beg, ending with a RS row.

SHAPE NECK ANGLE

Work short rows as follows, working wrap together with wrapped st as you come to them:

(WS) Purl 2, wrp-t. (RS) Knit across.

(WS) Purl 5, wrp-t. (RS) Knit across.

(WS) Purl 8, wrp-t. (RS) Knit across.

(WS) Purl across all sts,

Cont in St st, work even until piece measures 9 (9 1/2, 10) inches from short rows, ending with a WS row.

SHAPE SHOULDER/NECK EDGE

Note: This shaping is to bring the inner edge of front band up to the level of the garment front, to compensate for the fact that at this point the trim band is being worked at an angle from the previous short rows – it is worked in the opposite direction from normal shoulder shaping.

Work short rows as follows, working wrap together with wrapped st as you come to them:

(RS) Knit 3, wrp-t. (RS) Purl across.

(RS) Knit 6, wrp-t. (RS) Purl across.

(RS) Knit 9, wrp-t. (RS) Purl across.

(RS) Knit across all sts,

Bind off loosely. Sew trim to lower edge and center front, easing short row angle shaping to fit.

RIGHT FRONT – CC trim

Work as for left front trim, reversing all shaping.

FINISHING

Block pieces to measurements. Sew shoulder seams, matching center front edge to marker on back CC trim. Set in sleeves; sew sleeve and side seams.

CORD TRIM

Measure around seams between garment pieces and CC trim; add 1 – 2 inches to this measurement – it's easier to unravel a few rows than to try to make a too short piece longer. Using Embellish-Knit! Automatic spool knitter and CCA, work 2 pieces of cord the width of the sleeves, (one for each sleeve), and 1 piece of cord to fit around back and fronts of jacket (see photo). Using sewing needle and matching thread, neatly tack cording over seams between garment pieces and trim. Adjust final length and neatly joins ends of cord. Using tn, weave in all ends.

SCARF

Using larger needles and CCB, cast on 15 sts.

(RS) Beg St st; work even until piece measures 44 inches from beg.

Bind off all sts loosely. Using tn, weave in all ends.

FRINGE

Using MC, cut 40 strands 12" long. Holding 4 strands together, fold fringe in half. Using crochet hook, * insert hook from WS to RS into first st at corner of one short end of scarf, pull through loop [fold of strands], insert ends into loop and pull tight against edge; repeat from *, attaching 5 fringes to each short end of scarf.

CH3S - Jubilee Jacket and Scarf
Chart and Schematic

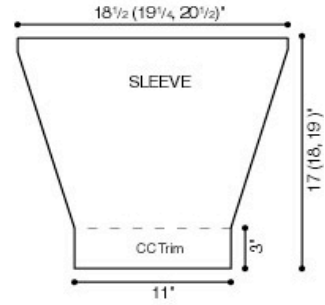
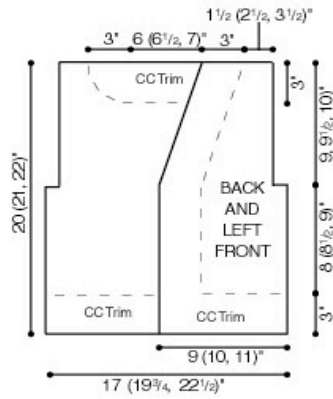
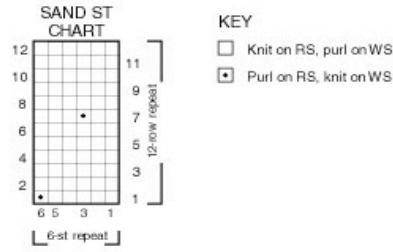

|| Yarns || Free Projects || Where to Buy || Links || Learning || Contact Us || Caron Connections || News ||
Latch Hook ||

Visit Bond America online

©2007 Caron International